

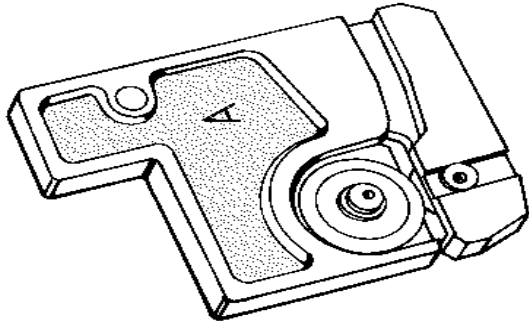

ALUMINUM CUTTER

Old # 04-115 - New #12-224

The Fletcher 3100 cuts glass, acrylic, foam board and hardboard using any one of four interchangeable pillar posts. A fifth pillar post is now available which permits the user to cut aluminum sheet up to .040 inch thick.



This pillar post appears similar to the hardboard cutter, but is different and is distinguished by an “A” stamped on the face as seen at the left. Do not attempt to cut aluminum with the hardboard pillar post or hardboard with the aluminum pillar post.

HOW TO CUT ALUMINUM

1. The aluminum cutting pillar post is inserted in the right hand slot of the cutting head in the same position as the hardboard cutting pillar post, and is secured with the speed screw. Refer to Figure 14, page 10 of the Fletcher 3100 Owner’s Manual, form 0594. The cutting technique is very similar to cutting hardboard. See page 20 for reference. Please note the procedure for using the 3100 measuring stop.
2. Set the measuring stop so the black stop lever aligns with the desired dimension on the scale. Then flip the white stop lever over and locate the edge of the aluminum against the white stop lever. Apply the clamp to secure the aluminum.
3. Depress the short thumb lever and raise the cutting head above the aluminum. Release the thumb lever and lower the cutting head until the wheels touch the aluminum. Do not strike the aluminum aggressively.
4. Firmly pull the cutting head down to its stop position. Release the clamp and remove the aluminum pieces.

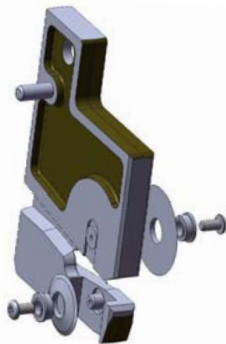

Replacement cutting wheels are available as a set, order #05-716. The illustration at left shows the sequence of assembly.